



**Wood-Mizer®**



# INTRODUCING WOOD-MIZER LOG SPLITTERS

HEAVY-DUTY LOG SPLITTERS NOW AVAILABLE FROM THE WORLD'S LEADING PORTABLE SAWMILL MANUFACTURER



# Welcome to the world of Wood-Mizer Log Splitters

Wood-Mizer Log Splitters are engineered for performance and built in the USA to provide you with the best available wood splitting equipment on the market. Offering three portable log splitter models for any sized firewood operation, the FS300, FS350, and FS500 Log Splitters all offer the highest-quality equipment and service you expect from Wood-Mizer. Standard features on our complete line of Log Splitters include:

- Solid and Rugged Construction
- Back-Saving Working Height
- Smart and Efficient Operator Location
- Accurate and Uniform Splitting
- Quick and Easy Setup
- Completely Portable

At Wood-Mizer we strongly believe “The Proof is in the Performance” and anyone seriously considering the purchase of a log splitter deserves to see it in action.

We encourage you to contact your local Wood-Mizer representative to see a live demonstration at one of our branch locations or at one of the many shows we attend each year. With many additional features including bi-directional log splitting, heavy-duty log lift, electric start, and skid-steer mount models, the Wood-Mizer Log Splitters are perfect for your farm, home, or commercial wood splitting operation.



## WOOD-MIZER LOG SPLITTERS AT A GLANCE:

MODEL	SPLITTING DIRECTION	SPLITTING FORCE	WEDGES	MOTOR	STARTER	HYDRAULIC PUMP	BUILT IN TRAILER	LOG LIFT	SKID STEER
FS300	One Direction	29 Tons	3 Way 4 or 5 Way	390 cc Honda	Electric	2-Stage, 22 GPM	Standard	Optional	N/A
FS350	Bi-directional	29 Tons	3 Way 4 or 5 Way	390 cc Honda	Electric	2-Stage, 22 GPM	Standard	Optional	Optional
FS500	Bi-directional	42 Tons	3 Way 4 or 5 Way	630 cc Honda	Electric	2-Stage, 28 GPM	Standard	Standard	N/A

### WEDGE CHOICES:

**INCREASE EFFICIENCY WITH THE UNIQUE DESIGN OF SPLITTING WEDGES THAT PRODUCE ACCURACY & CONSISTENT PIECES WITH NO NEED FOR RE-SPLITTING.**

OPTIONS: STANDARD 3-WAY WEDGE, 4-WAY WEDGE, OR 5-WAY WEDGE.

WEDGE REPLACEMENT SOLD SEPARATELY - CALL FOR PRICING.

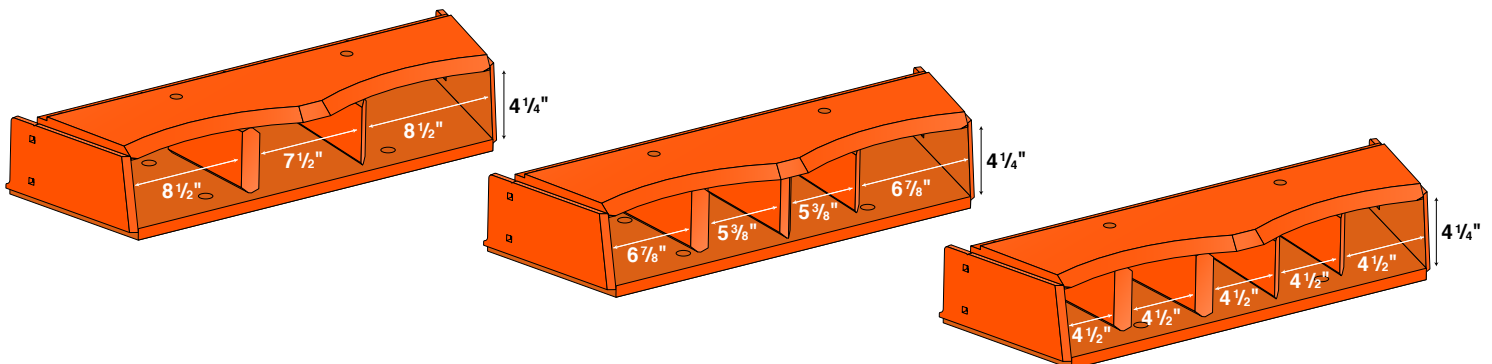

Engineered for Performance, just what you'd expect from Wood-Mizer.

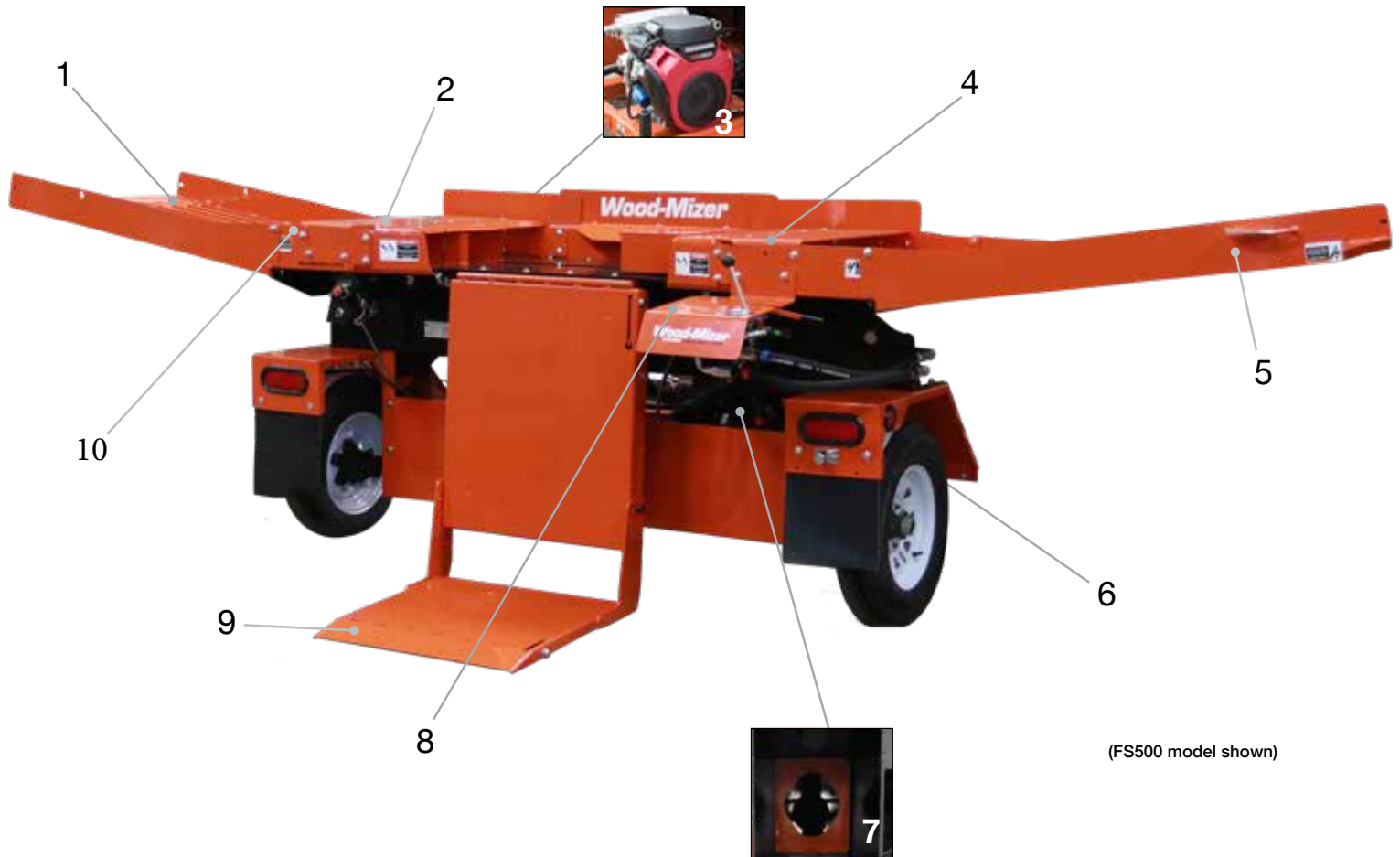

(FS500 model shown)

## FEATURES:

### 1. LONG LASTING AND TOUGH

The powder coated paint finish provides rugged durability plus a high quality and attractive finish.

### 2. DOUBLE YOUR PRODUCTION

Bi-directional push block increases production up to two times more than one-directional splitters. (FS350 & FS500 Models)

### 3. DEPENDABLE COMMERCIAL POWER

Honda engine offers performance and reliability.

### 4. INCREASE EFFICIENCY

Unique design of 3, 4 & 5-way splitting wedges produce accurate and consistent pieces with no need for re-splitting.

### 5. COMFORTABLE AND CONVENIENT

Extra wide wing trays collect split pieces while keeping them at working height for stacking or building.

### 6. COMPLETELY PORTABLE

Featuring a 3,500 lb torsion axle, stabilizing hitch, and LED lights for towing.

### 7. READY TO WORK

Heavy duty, tube-in-tube steel frame, and three-times the weight of standard log splitters.

### 8. CONVENIENT OPERATOR CONTROL PANEL

Dependable manual valves are conveniently located near operator.

### 9. INCREASE PRODUCTIVITY

Log lift conveniently positioned on the operator's side for fast and simple loading by a single operator.

### 10. SAVE YOUR BACK

Ergonomically-designed deck level 12" higher than comparable splitters.

# FS500

## LOG SPLITTER

The Wood-Mizer FS500 Log Splitter is perfect for bundle wood or firewood businesses looking to maximize efficiency and productivity. Producing 42 tons of force with a rugged 630 CC engine, the FS500 splits wood in both directions and produces up to three cords of firewood an hour with a 4.5 second cycle time. Featuring a heavy-duty trailer package, 2-stage hydraulic pump, oil cooler, log lift, and electric start, this fully-loaded splitter is equipped with a 3-way wedge and offers upgrades to 4-way or 5-way wedges making it a versatile all-in-one log splitter.



Part #: **FS500G630** \$18,995\*

### FS500 SPECIFICATIONS\*

DIMENSIONS (FS500G630)	IMPERIAL	METRIC
Operational Footprint	12' x 15' x 44"	3.6 m x 4.5 m x 1.1 m
<b>SPLITTING CAPACITY</b>		
Splitting Function	Bi-Directional	
Maximum Log Length	24"	609 mm
Optimum Log Diameter	24" - 26"	609 mm - 660 mm
Production Rate**	up to 3 cords/hr	
Cycle Time (sec)	4.5	
Splitting (tons/psi)	42 tons	38 metric tons
<b>MACHINE</b>		
Engine Type/Size	Honda Gas/630 cc	
Starter	Electric Start	
Oil Cooler	Standard	
Pump (gpm)	2 Stage - 28 GPM	2 Stage - 105.9 LPM
Hydraulic Tank Capacity	20 G (System Cap. 25 G)	75 L (System Cap. 94 L)
Cylinder Size	6"	152 mm
Frame Construction	Tube-in-tube steel	
Log Lift	Standard	
Wing Trays	Standard	
<b>WEDGE UPGRADES PRICING</b>		
WEDGE REPLACEMENT SOLD SEPARATELY - CALL FOR PRICING.		
3-Way Wedge 4" H (101 mm)	Standard	
4-Way Wedge 4" H (101 mm)	Optional \$300/set*	
5-Way Wedge 4" H (101 mm)	Optional \$600/set*	
5-Way Bundle 3.5" H (88 mm)	Optional \$600/set*	
<b>TOWING</b>		
Trailer	Standard	
Axle (Torsion/lbs)	3,500 lbs.	1,587 kg
Hitch	2" SAE4	50 mm SAE4
<b>SHIPPING</b>		
Shipping Pallet	88" x 60"	2.2 m x 1.5 m
Shipping Weight	2,960 lbs	1,342 kg
<b>WARRANTY</b>		
	1 Year Limited	



**COMPLETELY PORTABLE**  
FEATURES A 3,500 LB TORSION AXLE, STABILIZING HITCH, SAFETY CHAINS AND LED LIGHTS FOR TOWING.



**STANDARD WITH TWIN FLUTED WING TRAYS** TO SEPARATE THE DEBRIS. (SHOWN WITH OPTIONAL 4-WAY WEDGE)



**SIMPLE SHIPPING AND ASSEMBLY**  
Shipped on a single 88" x 60" pallet and assembled in minutes with only 7 bolts to secure before operation.



\* Prices and specifications are subject to change without notice.

# FS350

## LOG SPLITTER

The Wood-Mizer FS350 Log Splitter is ideal for commercial, farm, and at home wood splitting. Featuring a heavy-duty trailer and 2-stage hydraulic pump, the FS350 combines 29 tons of force with a 390cc gas engine to provide the necessary power and portability for nearly any type of splitting operation. The rugged FS350 Log Splitter produces uniform firewood pieces at double the rate of other log splitters with the standard bi-directional push block and 3-way wedge. Options include 4-way or 5-way wedge upgrades, log lift, and electric start.

Part #: **FS350G390 \$15,350\***  
**Log Lift Option: FS350-LL \$1,425\***



FS350 Shown with  
Optional Log Lift



**BIDIRECTIONAL  
PUSH BLOCK  
PRODUCES UNIFORM  
FIREWOOD PIECES  
AT DOUBLE THE  
RATE OF OTHER LOG  
SPLITTERS.**



**COMPLETELY  
PORTABLE**  
Featuring a 2,200 lbs  
torsion axle, stabilizing  
hitch, and LED lights  
for towing.

### FS350 SPECIFICATION

DIMENSIONS	IMPERIAL	METRIC
Operational Footprint	10' x 6' x 36"	3 m x 1.8 m x 914 mm
<b>SPLITTING CAPACITY</b>		
Splitting Function	Bi-Directional	
Maximum Log Length	24"	609 mm
Optimum Log Diameter	24" - 26"	609 mm - 660 mm
Production Rate**	up to 2 cords/hr	
Splitting (tons/psi)	29 tons	26 metric tons
<b>MACHINE</b>		
Engine Type/Size	Honda Gas/390 cc	
Starter	Electric Start	
Pump (gpm)	2 Stage - 22 GPM	2 Stage - 83.2 LPM
Hydraulic Tank Capacity	18 G (System Cap. 23 G)	68 L (System Cap. 87 L)
Cylinder Size	5"	127 mm
Frame Construction	Tube-in-tube steel	
Log Lift	Optional	
Wing Trays	Two	
<b>WEDGE UPGRADES PRICING</b>		
WEDGE REPLACEMENT SOLD SEPARATELY - CALL FOR PRICING.		
3-Way Wedge 4" H (101 mm)	Standard	
4-Way Wedge 4" H (101 mm)	Optional \$300/set*	
5-Way Wedge 4" H (101 mm)	Optional \$600/set*	
5-Way Bundle 3.5" H (88 mm)	Optional \$600/set*	
<b>TOWING</b>		
Trailer	Standard	
Axle (Torsion/lbs)	2,200 lbs.	998 kg
Hitch	2" SAE4	50 mm SAE4
<b>SHIPPING</b>		
Shipping Pallet	88" x 66"	2.2 m x 1.6 m
Shipping Weight	2,050 lbs.	930 kg
<b>WARRANTY</b>	1 Year Limited	

\* Prices and specifications are subject to change without notice.

# FS350 SKID STEER LOG SPLITTER

The FS350 skid steer log splitter is a powerful wood splitter engineered for farming and ranching operations that already have a skid steer loader or front loader. By connecting two hydraulic hoses, the FS350SS is powered by the skid steer's existing power plant which lowers the initial cost of investment. The rugged FS350SS produces uniform firewood pieces at double the rate of other log splitters with the standard bi-directional push block and 3-way wedge. Options include 4-way or 5-way wedge upgrades and log lift.



**Part #: FS350SS \$9,475\***  
**Log Lift Option: FS350-LL \$1,425\***



**FS350SS SKID STEER MODEL** FS350SS is designed to attach to skid-steer machines through an auxiliary hydraulic power pack. Call for details.



**BIDIRECTIONAL PUSH BLOCK** PRODUCES UNIFORM FIREWOOD PIECES AT DOUBLE THE RATE OF OTHER LOG SPLITTERS.



**SIMPLE SHIPPING AND ASSEMBLY** Shipped on a single 88" x 66" pallet.

### FS350 SKID-STEER SPECIFICATIONS\*

DIMENSIONS	IMPERIAL	METRIC
Operational Footprint	10' x 6' x 36"	3 m x 1.8 m x 914 mm
<b>SPLITTING CAPACITY</b>		
Splitting Function	Bi-Directional	
Maximum Log Length	24"	609 mm
Optimum Log Diameter	24" - 26"	609 mm - 660 mm
Production Rate**	up to 2 cords/hr	
Splitting (tons/psi)	29 tons	26 metric tons
<b>MACHINE</b>		
Skid Steer Plate	Standard	
Skid Steer Hook Ups	3/4" NPT Hose	19 mm NPT Hose
GPM (for skid-steer)	22 GPM (max. 28 GPM)	83 LPM (max. 106 LPM)
PSI (for skid-steer)	2,500 - 3,000 lbs max.	1,134 - 1,360 kg max.
Cylinder Size	5"	127 mm
Frame Construction	Tube-in-tube steel	
Log Lift	Optional	
Wing Trays	Two	
<b>WEDGE UPGRADES PRICING</b>		
WEDGE REPLACEMENT SOLD SEPARATELY - CALL FOR PRICING..		
3-Way Wedge 4" H (101 mm)	Standard	
4-Way Wedge 4" H (101 mm)	Optional \$300/set*	
5-Way Wedge 4" H (101 mm)	Optional \$600/set*	
5-Way Bundle 3.5" H (88 mm)	Optional \$600/set*	
<b>SHIPPING</b>		
Shipping Pallet	88" x 66"	2.2 m x 1.6 m
Shipping Weight	2,050 lbs	930 kg
<b>WARRANTY</b>	1 Year Limited	

\* Prices and specifications are subject to change without notice.



## **GIVE YOUR AXE THE AXE.**

This is not your grandfather's firewood splitter. Dual action wood splitting, reliable heavy-duty hydraulics, comfortable working height, and powerful commercial-rated splitting force make fast and easy work of your firewood rounds, wood chunks, and more so you can give your axe the axe and never look back.



Global Headquarters and blades manufacturing facility in Indianapolis, IN.



North America manufacturing facility in Batesville, IN.



**SERVING YOU FROM COAST TO COAST.**

- |   |   |   |   |   |   |
|---|---|---|---|---|---|
| <p>1 <b>WOOD-MIZER LLC<br/>GLOBAL HEADQUARTERS<br/>INDIANA</b><br/>8180 West 10th St.<br/>Indianapolis, IN 46214<br/><b>317.271.1542</b></p> <p><b>WOOD-MIZER BATESVILLE</b><br/>1646 Lammers Pike<br/>Batesville, IN 47006<br/><b>800.553.0182</b></p> | <p>2 <b>NEW YORK</b><br/>8604 State Route 104<br/>Hannibal, NY 13074<br/><b>315.564.5722</b></p> <p>3 <b>GEORGIA</b><br/>74 Pine Rd.<br/>Newnan, GA 30263<br/><b>770.251.4894</b></p> <p>4 <b>OREGON</b><br/>24435 N.E. Sandy Blvd.<br/>Wood Village, OR 97060<br/><b>503.661.1939</b></p> <p>5 <b>MISSOURI</b><br/>9664 Lawrence 2130<br/>Mt. Vernon, MO 65712<br/><b>417.466.9500</b></p> | <p>6 <b>PENNSYLVANIA</b><br/>22638 Croghan Pike<br/>Shade Gap, PA 17255<br/><b>814.259.9976</b></p> <p>7 <b>MAINE</b><br/>541 Borough Rd.<br/>Chesterville, ME 04938<br/><b>207.645.2072</b></p> <p>8 <b>CALIFORNIA</b><br/>6980 Camp Far West Rd.<br/>Sheridan, CA 95681<br/><b>530.633.4316</b></p> <p>9 <b>ALASKA</b><br/>10661 Elies Drive<br/>Anchorage, AK 99507<br/><b>907.336.5143</b><br/><b>907.360.2497</b></p> <p>10 <b>NORTH CAROLINA</b><br/>548 W Red Cross Rd<br/>Oakboro, NC 28129<br/><b>704.982.1673</b></p> | <p>11 <b>WISCONSIN</b><br/>218222 County Rd O<br/>Mosinee, WI 54455<br/><b>715.432.6018</b></p> <p>12 <b>COLORADO</b><br/>100 Tailwinds Drive<br/>Buena Vista, CO 81211<br/><b>719.301.6035</b></p> <p>13 <b>MONTANA</b><br/>209 Thompson Road<br/>Boulder, MT 59632<br/><b>406.220.6055</b></p> <p>14 <b>TEXAS</b><br/>11606 Highway 96 South<br/>Kirbyville, TX 75956<br/><b>409.423.2319</b></p> <p>15 <b>MISSISSIPPI</b><br/>1128 Liberty Road<br/>Louisville, MS 39339<br/><b>662.803.4332</b><br/><b>662.617.1841</b></p> | <p>16 <b>CANADA<br/>HEADQUARTERS<br/>ONTARIO</b><br/>396 County Rd 36 Unit B<br/>Lindsay, ON<br/>Canada K9V 4R3<br/><b>705.878.5255</b></p> <p>17 <b>CANADA - QUEBÉC</b><br/>34 Rue Nord<br/>Waterloo, QC<br/>Canada J0E 2N0<br/><b>450.539.1114</b></p> <p>18 <b>CANADA - ONTARIO<br/>NORTH</b><br/>179 Intola Rd<br/>Murillo, ON<br/>Canada P7G 0T4<br/><b>807.683.9243</b></p> | <p>19 <b>CANADA - WEST</b><br/>4770 46th Avenue S.E.<br/>Salmon Arm, BC<br/>Canada V1E 2W1<br/><b>250.833.1944</b></p> <p>20 <b>CANADA - WEST</b><br/>(Vancouver Island)<br/>1124 Clarke Rd<br/>Qualicum Beach, BC<br/>Canada V9K 1W3<br/><b>250.752.3994</b></p> <p>21 <b>CANADA - EAST</b><br/>579 Main Street<br/>Shediac, NB<br/>Canada E4P 2C6<br/><b>506.532.5566</b></p> |
|---|---|---|---|---|---|

**800.553.0182 | woodmizer.com**

